

**INFLUENCE OF 5E-TEACHING CYCLE ON ATTITUDE, RETENTION AND ACADEMIC PERFORMANCE OF STUDENTS WITH VARIED ABILITY IN SELECTED SECONDARY SCHOOLS IN ZARIA EDUCATION ZONE, KADUNA STATE NIGERIA**

**Dr. Binta A. Muhammad<sup>1</sup>, Dr. Efe M. Omwirhiren<sup>2</sup> and Salisu Abubakar<sup>3</sup>**

Department of Chemistry Federal College of Education, P.M.B. 1041, Zaria Nigeria.

Email Address: <sup>1</sup>amirabintafce@gmail.com, <sup>2</sup>omwirhirenefe83@gmail.com, <sup>3</sup>salismabera@yahoo.com

**ABSTRACT**

This study investigated the Influence of 5E teaching cycle on Attitude and Academic, Performance of Chemistry Students of varied abilities in Mole Concepts among Senior Secondary School in Zaria Educational Zone. A Quasi-experimental pretest and posttest research design was used for the study which featured two groups (Experimental and Control group). Sample sizes of 200 students selected from two secondary schools in Zaria Metropolis were used as the study sample, drawn from a population of 11 schools with a total of 1154 students. The two schools randomly selected, were selected after matching them, to find their equivalent academically. The Instrument developed; Mole Concept Performance Test (MCPT) with a reliability coefficient of 0.88 was used to collect data for pretest and posttest. The data collected were analyzed using Analysis of Covariate (ANCOVA) and Kruscal Wallis test statistics at  $P \leq 0.05$  level of significance. The findings of the study showed that science (Chemistry) students exposed to 5E teaching cycle in the teaching and learning of mole concepts in all the ability levels had higher mean performance scores than those in the control group exposed to lecture method of instruction. The attitude of the students in the experimental groups improved significantly after exposure to 5E teaching cycle. Recommendations were made based on the findings which is: The teaching of Chemistry particularly mole concept should be conducted using 5E teaching cycle as it makes students learn meaningfully and help them to develop positive attitude towards chemistry. It should therefore be incorporated into the main stream of pedagogy in the teaching of Chemistry and other related Science subject in Zaria Education zone, Kaduna, Nigeria.

**KEYWORDS:** Entrepreneurship education, graduates employments,

**INTRODUCTION**

Science educators have been advocating the need for science instruction at all levels to focus on the enhancing student conceptual understanding higher level of performance in scientific thinking reasoning and problem solving (Chin & Chia, 2005) this advocacy is in consistent with various reform initiative around the globe, for both science and mathematics curricula and classroom practices, the need to develop student conceptual understanding and scientific literacy by using inquiry and problem – solving experience and skills acquisition have been emphasized in the united states reform document of the American Association for the Advancement of Science (AAAS, 2008) and National Research council (N.R.C, 2007). Science teachers continuously strive to improve their

instructional practices to enhance student learning.

According to O' Brien (2013) 5E teaching cycle is an instructional model for designing a series of experientially rich lessons that are conceptually linked and developmentally sequenced to support the ongoing, progressive refinement in student understanding as it develops over time. By bee, (2009) sees 5E teaching cycle as an instructional model based on the constructivist approach to learning which says that learners build or construct new ideas on top of their old ideas. The 5E teaching cycle allows students and teachers to experience common activities, to use and build on prior knowledge and experience, to construct meaning and to continually assess their understanding of a concept. The importance of 5E teaching cycle in the science process cannot be overemphasized and thus, the National Research Council (NRC 2000) created the standards around a central theme science standard for all students.

Several studies revealed that 5E teaching cycle enhanced better performance among students in chemistry students (Ceylan, 2008; Pulat, 2008, Baser, (2008), Pulat (2009) , Shitu (2013) and Ado,(2014), Ibrahim (2015) reported that 5E learning cycle is considerably more effective than conventional classroom instruction respectively. However, Ridgeway (2004) and Idris (2012) found no significant difference in the achievement of students taught chemistry using 5E teaching cycle and those taught using conventional classroom respectively. The findings on the use of 5E teaching cycle are inconclusive; therefore, this study examined the effects of 5E teaching on students' performance of varied ability in mole concept in Zaria Education zone.

However, students' attitude (opinion and general feeling) towards chemistry need to be assessed during the lesson so that the teacher can know how the students feel towards the teaching strategies, subject matter and classroom activities. Studies have proven that 5E learning cycle has been very effective in encouraging students' interaction and developing positive attitudes towards learning (Wilder Bybee et al. (2006); Ceylan (2008), Akinbobola (2009), Bunkure (2012), Umahaba, (2016),) revealed that percentage of students who prefer cooperative learning is higher than the percentage of students who do not like cooperative learning.

The poor achievement in chemistry has been persistent in such way that students enrolment in Nigeria tertiary institutions indicate that an over whelming proportion are in the art and humanities, rather than science and science based courses (Njoku, 2014). Students persistent mass failure has been attributed to many factors among which are the many chemistry topics which research has identified to be difficult for students to learn, some of the difficult concepts include heat capacities, nuclear reactions chemical energetic and mole concepts among others), Chief examiners report (WAEC, 2010 and 2011). Chemistry students usually find these concepts very difficult due to the high level of abstraction and teachers often do not have enough resources to make them more concrete. Mole concept is one of the concepts students find difficult to learn. Therefore teaching the concept using more concrete approaches has reduced students learning difficulties. The 5E teaching

cycle would be used in teaching to reduce the level of abstraction and to find out whether learning difficulties in mole concepts would be remediated.

Based on these facts the present study examined the effects of 5E teaching cycle strategy on academic performance and attitudes among students of varied ability taught mole concept in chemistry.

### **OBJECTIVES OF THE STUDY**

The following objectives were set for the study, to:

1. Determine the academic performance of secondary school chemistry students of varied abilities in mole concepts after exposure to 5E teaching cycle.
2. Find out the change if any in attitude towards mole concept between secondary school students of varied abilities exposed to 5E teaching cycle.

### **RESEARCH QUESTIONS**

The research questions formulated for the study are as following:

1. What is the difference in the academic performance of secondary school students with varied abilities taught mole concept using 5E teaching cycle and those taught same concepts using the conventional lecture method?
2. Is there any difference in the attitudinal change of secondary school students of varied abilities taught mole concept using 5E teaching cycle?

### **NULL HYPOTHESES**

The null hypotheses formulated for the study are as follows:

**Ho1:** There is no significant difference in the academic performance between secondary school chemistry students of varied abilities taught mole concept using 5E teaching cycle and those taught same concepts using the conventional lecture method.

**Ho2:** There is no significant difference in the attitudinal change between secondary school students of varied abilities taught mole concept using the 5E teaching cycle and those taught same concepts using the conventional lecture method.

### **METHODOLOGY**

The Research Design adopted for this study was the pretest-posttest Quasi Experimental and Control group design proposed by Kerlinger (2005). For this study, the subjects were pretested to ascertain the academic equivalence. The group with close academic equivalence and no significant difference was assigned into the experimental and control group respectively using the balloting method. The experimental group was taught using the 5Es Teaching Cycle Model for four (4) weeks according to the scheme of work and mole concepts chosen for the study, while the control group was taught same mole concepts by the use of lecture method for the same period. After a treatment, the posttest was administered to the groups to evaluate the effectiveness of the treatment on their Academic

Performance, and Attitude before and after exposure to 5Learning Cycle instructional Model. The students" in the experimental group was observed. Post-test was administered in two weeks interval after the treatment to determine the retention ability of the student, this is in accordance with Tuckman (1975).

An illustration of the Research Design is shown in Figure 1

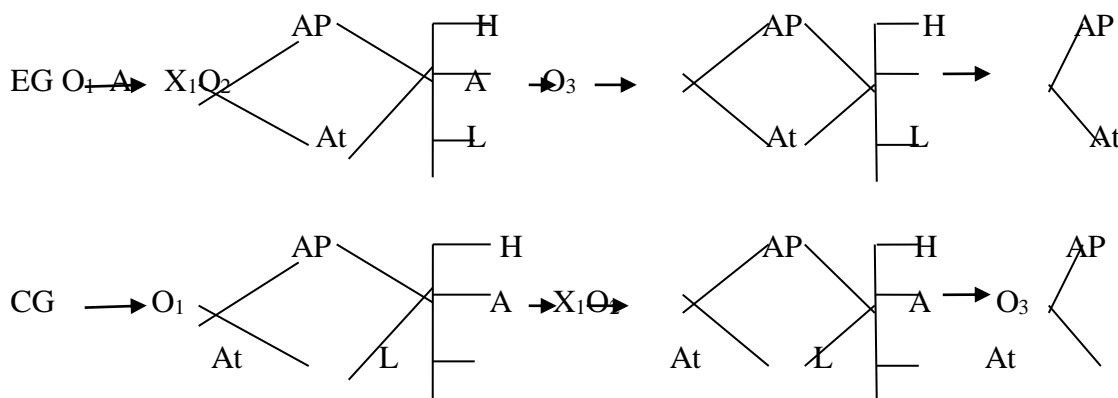

Fig 1: Research design Illustration

**Research Design**

Where:

EG - Experimental Group (Will be Taught with 5Es Learning Cycle Model), arrange vertically

CG - Control Group (Lecture Method) ,X<sub>1</sub> - Treatment with 5Es Learning Cycle Model

X<sub>0</sub> - Treatment with Lecture Method, O<sub>1</sub> - Pretest, O<sub>2</sub> - Post-test,O<sub>3</sub>-Postpost test,

H-High ability group, A- Average ability group, L - Low ability group,

AP- Academic Performance, At – Attitude.

**POPULATION OF THE STUDY**

The population of this study comprised of all public co-educational Senior Secondary Schools (SS II) Students offering Chemistry as a subject in Zaria Education zone. The public coeducational schools were selected for use in this study because of their convenience, availability of infrastructure, population, readiness to assist the researcher when conducting research, gender equality among others. There are eleven senior secondary schools with a total of 1,154 students. 711 students are males and 443 students are females. Detail of the population is shown in Table 1

**Table 1 Population of the Study**

| S/No. | Name of School              | Location  | SSII<br>Enrolment<br>No of Male | No of<br>Female | Total        |
|-------|-----------------------------|-----------|---------------------------------|-----------------|--------------|
| 1     | Govt. Senior Sec Sch Muchia | SabonGari | 65                              | 50              | 135          |
| 2     | Govt. Sec. Sch. Aminu       | SabonGari | 70                              | 43              | 113          |
| 3     | GSS Magajia                 | Zaria     | 74                              | 36              | 110          |
| 4     | GSS Chindith Barak          | SabonGari | 108                             | 100             | 208          |
| 5     | GSS T/ Jukun                | Zaria     | 74                              | 49              | 123          |
| 6     | GSS Gyalesu                 | Zaria     | 48                              | 29              | 77           |
| 7     | GSS KofarKuyanBana          | Zaria     | 56                              | 32              | 88           |
| 8     | SIASSS Karau-Karau          | Zaria     | 42                              | 21              | 63           |
| 9     | GSS Dakace                  | SabonGari | 87                              | 35              | 122          |
| 10    | GSS Likoro                  | SabonGari | 57                              | 25              | 82           |
| 11    | GSS Karaukarau B            | Zaria     | 30                              | 23              | 53           |
|       | <b>Total</b>                |           | <b>711</b>                      | <b>443</b>      | <b>1,154</b> |

### 3.4 SAMPLE AND SAMPLING TECHNIQUES

The samples were selected using simple random sampling technique. To select the sampled schools, the names of the eleven senior public co-educational schools were written on pieces of paper and put in a container and one piece of paper was picked at a time. Any school whose name appeared on the paper was taken as one of the two schools to serve as sample. The remaining pieces of papers were also reshuffled before another paper was picked and recorded. The process was repeated until all the two schools were selected. Two schools of academic equivalent were randomly selected. These schools were GSS Gyalesu which was randomly assigned experimental group and GSS TudunJukun which was used as control group. In each of these two schools, an intact class was used so that no student is left out. Therefore this study comprised of 200 students selected from the two schools, which are viable for the study and this is in line with the recommendation of Krejcie and Morgan (1970) that sample size of 200 students for a population of 1154 students is viable for quasi-experimental study.

**Table 2 Sample of the Study**

| S/No. | Name of School | Male       | Female    | Total      | Group        |
|-------|----------------|------------|-----------|------------|--------------|
| 1     | GSS Gyalesu    | 51         | 26        | 77         | Experimental |
| 2     | GSS TudunJukun | 74         | 49        | 123        | Control      |
|       | <b>Total</b>   | <b>122</b> | <b>78</b> | <b>200</b> |              |

### 3.6.1 VALIDATION OF THE INSTRUMENT

In an attempt to establish the validity of the Mole Concept Performance Test (MCPT) and Mole Concept Attitude Questionnaire (MCAQ) the instrument were subjected to scrutiny by one Secondary School Chemistry teacher with M.Sc. in Chemistry (Kaduna State) and two Ph.D holders with the rank of Senior Lecturer in the Department of Science Education, Ahmadu Bello University, Zaria.

#### Pilot Testing

The pilot testing was carried out using the instrument, Mole Concept Performance Test (MCPT) and Mole Concept Attitude Questionnaire (MCAQ) on fifty (50) SS II, Chemistry students of GSS Magajiya.

#### RELIABILITY OF THE INSTRUMENT (CPT)

The data obtained was analyzed to establish the reliability of the instrument. The test-retest method was used to test the reliability of the instrument (MCPT) within the interval of two weeks, this is in line with Tuckman, (1975) and Pearson Product Moment Correlation (PPMC) was used to determine the reliability of the instrument and test items. The reliability coefficient of the instrument was found to be  $r = 0.88$  While that of MCAQ was found to be 0.76, which indicate high correlation between the test. The result obtained therefore shows the suitability of the test item for the study. The pilot study provided data for the item analysis.

#### RESULTS

For the inferential analysis, which enable test of the research hypotheses ANCOVA and Kruscal wall is statistics was used.

HO1: There is no significant difference in the academic performance between secondary school chemistry students of varied abilities taught mole concept using 5E teaching cycle and those taught same concepts using the conventional lecture method. Analysis of Covariance (ANCOVA) statistics was used to test this hypothesis.

**Table 3: Analysis of Covariance (ANCOVA) of the Mean Scores of Experimental and Control Groups.**

| Source          | Type III Sum of Squares | df  | Mean Square | F        | Sig.  | Remark      |
|-----------------|-------------------------|-----|-------------|----------|-------|-------------|
| Corrected Model | 11202.913 <sup>a</sup>  | 6   | 1867.152    | 148.040  | .0001 | Significant |
| Intercept       | 29986.711               | 1   | 29986.711   | 2377.544 | .0001 |             |
| GROUP           | 2059.932                | 1   | 2059.932    | 163.325  | .0001 |             |
| ABILITY         | 8932.445                | 2   | 4466.222    | 354.112  | .0001 |             |
| GROUP * ABILITY | 924.012                 | 2   | 462.006     | 36.631   | .0001 |             |
| Error           | 2434.207                | 193 | 12.612      |          |       |             |
| Total           | 94600.000               | 200 |             |          |       |             |
| Corrected Total | 13637.120               | 199 |             |          |       |             |

Analysis of Covariance (ANCOVA) statistics presented in Table 3 showed that significant difference exists in the mean scores of chemistry students of varied abilities levels taught with 5E teaching cycle and their counterparts taught with lecture method. Reasons being that the intercept P-value of 0.001 is less than  $P \leq 0.05$  level of significance in both experimental and control group. Therefore the null hypothesis which states that there is no significant difference in the academic performance between secondary school chemistry students of varied abilities taught mole concept using 5E teaching cycle and those taught same concepts using the conventional lecture method is hereby rejected.

**Ho2:** There is no significant difference in the attitudinal change between secondary school students of varied abilities taught mole concept using the 5E teaching cycle.

**Table 4: KruskalWalis Analysis in the Attitude Change of Experimental Group**

|          | ABILITY | N  | Mean Rank | Sum of mean Rank | df | P-Value | Remark      |
|----------|---------|----|-----------|------------------|----|---------|-------------|
| Pretest  | H       | 20 | 66.40     | 112.95           |    |         |             |
|          | A       | 40 | 37.20     |                  |    |         |             |
|          | L       | 17 | 9.35      |                  |    |         |             |
|          |         |    |           |                  | 2  | 0.001   | Significant |
| Posttest | H       | 20 | 68.45     | 124.98           |    |         |             |

|  |       |    |       |  |  |  |  |
|--|-------|----|-------|--|--|--|--|
|  | A     | 40 | 37.53 |  |  |  |  |
|  | L     | 17 | 19.00 |  |  |  |  |
|  | Total | 77 |       |  |  |  |  |

Result of the Kruskal Wallis' Analysis in Table 4 showed that a significant difference exist in the attitude change of SSII chemistry students of varied abilities taught mole concept with 5E teaching cycle. This is simply because the P-value of 0.001 is less than  $P \leq 0.05$  alpha values. The mean rankings showed that in the pretest the attitude scores were 66.40, 37.20 and 9.35 for high, average and low abilities levels respectively. In the post- test scores the mean rankings showed that the attitude scores were 68.45, 37.53 and 19.00 for high, average and low abilities levels respectively. This shows that significant change has taken place between their pre-test and their post-test attitude scores in each of the three abilities groups. Therefore, the null hypothesis which states that there is no significant difference in the attitudinal change between secondary school students of varied abilities taught mole concept using the 5E teaching cycle is hereby rejected.

**DISCUSSION OF THE RESULTS**

This study investigated the influence of 5E teaching cycle on Attitude and Academic, Performance of Chemistry Students of varied abilities in Mole Concepts among Senior Secondary School Students in Zaria Educational Zone. The data collected from the post test administered were analyzed employing Analysis of Covariance (ANCOVA) and KruskalWalis test statistic at  $P \leq 0.05$  levels of significance.

Result from testing Hypothesis One shows that there is a significant difference in the mean academic performance scores of SS II Chemistry students of varied abilities exposed to 5E teaching cycle compared to those taught with lecture method. The significant difference found between the two groups is likely to be due to the use of 5E learning cycle (an activity-oriented method) on the experimental group. The result confirms earlier findings of(Campbell, 2000), Coulson,(2002); Boddy et al., (2003); Whilder & Shuttle worth, 2004; Ates, 2005 Garcia, 2005; Balcı, Çakıroglu and Tekkaya,2006; Ceylan, (2008), Bilgin (2009), Pulat (2009), Ado,(2014) and Ibrahim, (2015) who found that students exposed to inquiry method using 5E teaching cycle performed significantly better in the experimental groups than those in the control group .The study contradicts that of Rigdeway (2004) and Idris (2012) who found no significant difference in the mean achievement scores of students in the experimental and control group when taught with 5E learning cycle using inquiry method.

On the issue of 5E teaching cycle and students' attitude to mole concept, the results of hypothesis three showed that 5E teaching cycle enhanced positively the attitudes of high, average and low ability chemistry students to mole concept. This finding agrees with the findings of Wilder and



Bybee et al. (2006); Lakpini (2006), Ceylan (2008), Akinbobola (2009) Bunkure (2012), Umahaba, (2016) who found a significant attitude change of secondary school students of varied abilities compared with their counterparts in the control group.

### **CONCLUSION**

As a result of the findings in this study, it could be concluded that a better understanding, retention of mole concepts in Chemistry was provided by 5E teaching cycle. This is because all SS II students exposed to it, showed better performance when compared to those not exposed to it. Attitudes of SS II students exposed to 5E teaching cycle drastically increased than those taught with lecture method. This is because when students are taught through 5E teaching cycle strategy, they engaged themselves in solving practical activities such as experimentation, investigation and critical thinking.

### **RECOMMENDATIONS**

On the basis of findings emanating from this study, the following recommendations were made:

- i. The teaching of Chemistry especially mole concept and other difficult concepts should be conducted using 5E teaching cycle as it make students learn meaningfully, enhances better understanding of knowledge and develop positive attitude towards the subject. It should therefore be incorporated into the main stream of pedagogy in the teaching of chemistry students of varied abilities in all Senior Secondary schools of the zone.
- ii. Adequate funds should be provided by the government to sponsor Science teachers (Chemistry) teacher for retraining on 5E teaching required to improve academic performance of students.
- iii. Based on the findings, the study therefore recommends among others that, in service training for science teachers in form of seminars, workshops and conferences should focus more on how to use 5E teaching cycle for the teaching of mole concept concepts.

### **REFERENCES**

- Ado, I. K. (2014) Impact Of Constructivist Teaching Strategy In Students Academic Performance, Retention And Attitude Towards Trigonometry Among Senior Secondary Students In Kaduna State Niger Ph.D Thesis, Science Education Department A.B.U.
- Akinbobola, A. O. and Folashade, A. (2009). Constructivist problem-based learning technique and the academic achievement of physics students in Nigerian secondary schools. *Eurasian Journal of Physics and Chemistry Education*. 1(1): 45-51.
- Ates, S. (2005). The effectiveness of the learning cycle method on teaching DC circuits to prospective female and male science teachers. *Research in Science & Technological Education*, 23 (2), 213-227.
- Balci, S., Cakiroglus, J., &Tekkayas, C. (2006). Engagement, exploration, explanation, extension, and evaluation (5E) learning cycle and conceptual change text as learning tools. *Biochemistry and Molecular Biology Education*, 34(3), 199-203.
- Baser, E.T. (2008).Cited in Pulat S (2009). Impact of 5Es Learning Cycle on Sixth Grade Students"

Mathematics Achievement and Attitude towards Mathematic. M.Sc. Thesis of Middle East Technical University. Ankara, Turkey.

Bichi, S. S. (2002). Effects of Problem Solving Strategy and Enriched Curriculum on Secondary Schools Students Achievement in Evolution Concept. Unpublished PhD Dissertation, A.B.U. Zaria.

Bilgin, I.(2009).The effect of guided inquiry instruction incorporating a cooperative learning approach on university students achievement of acid and bases concept and attitude toward guided inquiry instruction. *Academic Journals: Scientific Research and Essay*,4 (10):1038-1046.

Biological Sciences Curriculum Study (BSCS). (2006). *BSCS Science: An Inquiry Approach*. Dubuque, IA: Kendall/Hunt Publishing Company.

Blank L. M. (2000). A Metacognitive Learning Cycle: A Better Warranty for Student Understanding. *Journal of Science Education*.84(4), 486-506.

Boddy N. Watson K. and Aubusson P. (2003). A Trial of the Five E's: A Referent Model For Constructivist Teaching and Learning. *Research in Science Education*.2(7), 59-61.

Bunkure, Y.I. (2012). Effect of a Constructivist Instructional Strategy on the Academic Achievement, Retention and Attitude to Physics among Secondary School Students of Different Ability Levels in Kano State, Nigeria. Unpublished Ph.D Dissertation, Department of Science Education, Ahmadu Bello University, Zaria. Bybee, R. W. (Ed) (2002). *Learning science and the science of learning*. Arlington, VA: NSTA Press.

Bybee, R., Taylor J., Gardner A., Scotter, P., Powell, J., Westbrook, A., &Landes, N., (2006).

The BSCS 5E Instructional Model: Origins, Effectives, and Applications. Executive Summary, BSCS, Colorado Springs, CO.

Çalık, M., Ayas, A., and Coll, R.K. (2010). Investigating the effectiveness of usage of different methods embed-ded with four-step constructivist teaching strategy. *Journal of Science Education and Technology*, 19(1), 32–48.

Campbell, M.A. (2000). The effects of the 5E learning cycle on students' understanding of force

and motionconcepts. M.Sc Thesis, University of Central Carlson, K. (2003). *Constructivism: What it Means for My Own Teaching*. Center for Development of Teaching and Learning.National University of Singapore.

Ceylan, E. (2008). Effects of 5e learning cycle model on understanding of state of matter and solubility concepts, Unpublished PhD Dissertation Thesis, Middle East Technical University, Ankara, Turkey.

Federal Republic of Nigeria (2013).National Policy on Education. Abuja: FME.

Felicia, O. and Peter, W. (2013). Enhancing Students' Achievement in Chemistry through the Piagetian Model: The Learning Cycle. *International Journal for Cross-Disciplinary Subjects in Education (IJCDSE)*, 4(4), 23-25

Ibrahim, T.S. (2015). Impact of 5Es learning cycle on academic performance, Retention and Attitude of Biology Students with Varied Abilities, North-West Zone, Nigeria. Unpublished Ph.D. Thesis.

Ahmadu Bello University Zaria. Idris, I.O. (2012). Effect of Concept Mapping Strategy on Mathematics Achievement and Attitude among Students with varied Ability Levels in Senior Secondary Schools in Zaria Education Zone. A Postgraduate Research Seminar Paper (EDSE 805),

Department of Science and Mathematics Education, Faculty of Education, Ahmadu Bello University, Zaria.

Kerlinger, F. N. and Lee, H. Z., (2005). *Foundation of Behavioural Research*. Forth Edition, New York: Harcourt Higher Learning Company.

Krejcie, R., Morgan, R.W., (1970). Determination of Sample Size for Research Approach. *Educational Psychology Measurement*. 30, 607-610

Lakpini, M. A. (2006). Effects of a Conceptual Change Instructional Strategy on the Achievement, Retention and Attitude of Secondary School Biology Students with Varied Ability. An Unpublished Ph.D Dissertation at the Department of Education, Ahmadu Bello University, Zaria.

Coulson A.E. (2002). *Science Teaching and Development of Thinking*. Wadsworth/Thomson Learning.

Muhammad B.A (2014) Influence of Conceptual Instructional Method on Students' Performance, and Attitude towards Practical Chemistry Among Students In Kaduna State, Nigeria. Ph.D Theses Department of Science Education, Faculty of Education, Ahmadu Bello University, Zaria Kaduna State Nigeria. National Research Council, (2000). *Inquiry and the National Science Education Standards*. Washington, DC: National Academy press.

Nuhoglu H, and Yalcin N (2006). The Effectiveness of the Learning Cycle Models to Increase Students Achievement in the Physics Laboratory. *Journal Turkish Science Education* 3(2), 28–30.

Njelita, C.B (2007). "Enhancing Science Process Skills Acquisition in Volumetric Analysis Using Co-operative Learning Strategy", *Journal of Chemistry panel workshop* 3(7), 32 – 34).

Njoku, Z. C. (2005). Level of Chemistry Practical Science Skills Acquired by Senior Secondary School (SSII) Students. *Nigeria Journal of Professionals Teachers*, 2(2). Nwosu, A. A. (2004). Teachers' Awareness of Creativity Related Behaviors Science Classroom. *Journal Science Teacher Association of Nigeria*. 39(1,2), 22-26.

Njoroge, U.N Changeiywo, J.M and Ndirangu M. (2014). Effect of inquiry-Based teaching approach on secondary school students achievement and motivation in physics in Nyeri Country, Kenya: *International Journal of Academic Research in Education and Review*. 2(1), 1-16

O'Brien T. (2013) 5E (2) . *Guidelines for Designing Research – informed Science Lesson Sequences*. NSTA press. Arlington, Virginia. Opara, A.J. (2011). Inquiry method and students academic deferent in Biology: Lesson and policy implication: *American-urasian journal of scientific research* 6(1) 28-31.

Pulat, S. (2009) *Impact Of 5e Learning Cycle On Sixth Grade Students' Mathematics Achievement On And Attitudes Toward Mathematics* . A Thesis Submitted To The Graduate School Of Social Sciences Of Middle East Technical University In Partial Fulfillment Of The Requirements For The Degree Of Master Of Science In The Department Of Elementary Science And Mathematics Education.

Renner, J. W., Abraham, M. R. & Birnie, H. H. (2015). The necessity of each phase of the learning cycle in teaching high school physics. *Journal of Research in Science Teaching* 25(1), 39-58.

Ridgeway, V.G. (2004). One teacher journey. *Journal of Adolescent and Adult Literacy*, 47(5):364-368.

Tuckman, B. W (1975). *Measuring Education Outcomes*. New York. Umahaba R. E (2016). Impact of 5es Learning Model on Questioning Style Preference and Academic Performance among Secondary School Chemistry Students, Katsina Metropolis, Nigeria

Wilder, M., & Shuttleworth, P. (2004). Cell inquiry: A 5E learning cycle lesson. *Science Activities*, 41(1), 25-31.